

Pilote : Edouard Hugon

Date : 04/10

Course : NEO RACE

Conditions de course

Météo : INDOOR

Type de piste : HARD PACKED/ JUMPS

Train avant

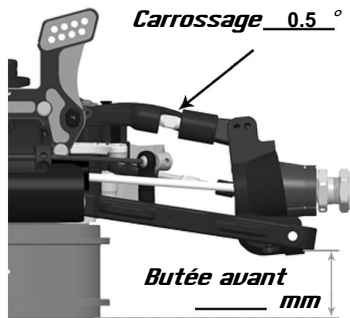

Position du tirant supérieur

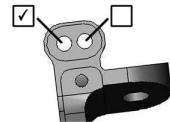

Anti-plongée 5 °

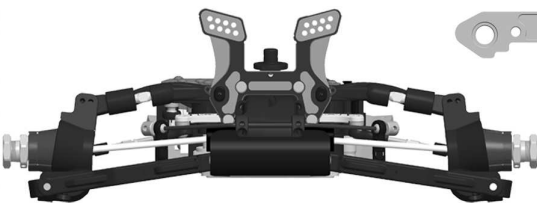
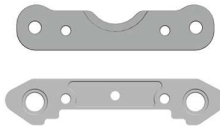

Pincement

Négatif 0 °
Positif 0 °

Train arrière

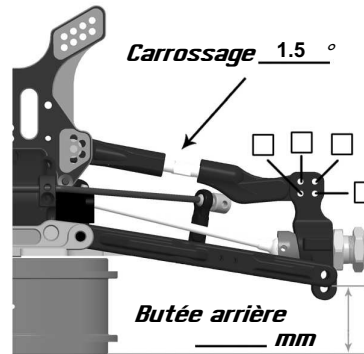

Position du tirant supérieur

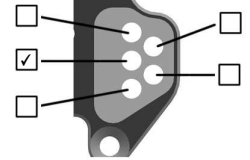

Position inférieure Etrier arrière

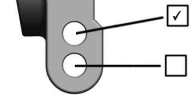

Pincement arrière 2.5 °

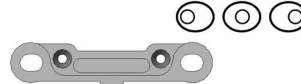

Anti-cabrage Standard

4 °

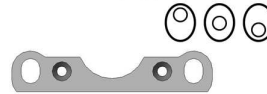

Empattement



Long
 Moyen
 Court

Barre anti-roulis 2.5 mm

Amortisseurs avant

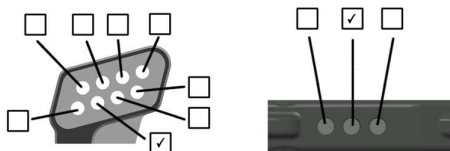

Type huile _____
Viscosité 600 W
Piston 6*1.25
Ressort hard
Cales _____ mm

Amortisseurs arrières

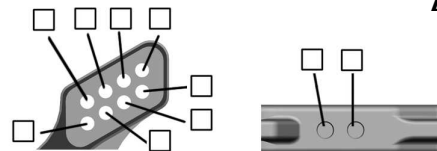

Type huile _____
Viscosité 500 W
Piston 6*1.3
Ressort medium
Cales _____ mm

Position Ackermann

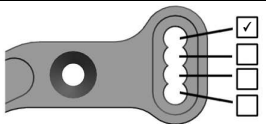

Position aileron

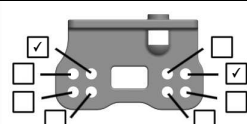

Hauteur du châssis



Type go 21 5 tuned
Décompression 1 Buse de réduction φ 7mm
Bougie ht t6 Carburant 33% merlin
Echappement go 2047

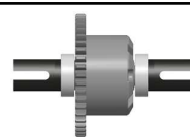

Type huile _____
Avant 6000 W Joint _____ Pcs
Central 6000 W _____ Pcs
Arrière 8000 W _____ Pcs



Avant

Type _____
Mousse _____
Gomme _____

Arrière

Type _____
Mousse _____
Gomme _____



Masselottes embrayage :

Aluminium Carbones
Ressort soft _____ mm
Cloche / Couronne centrale 13/46

Résultats

Temps / tours _____
Meilleur tour _____

Commentaires

proto spirit